

ICI CALDAIE

TECHNICAL MANUAL

GB

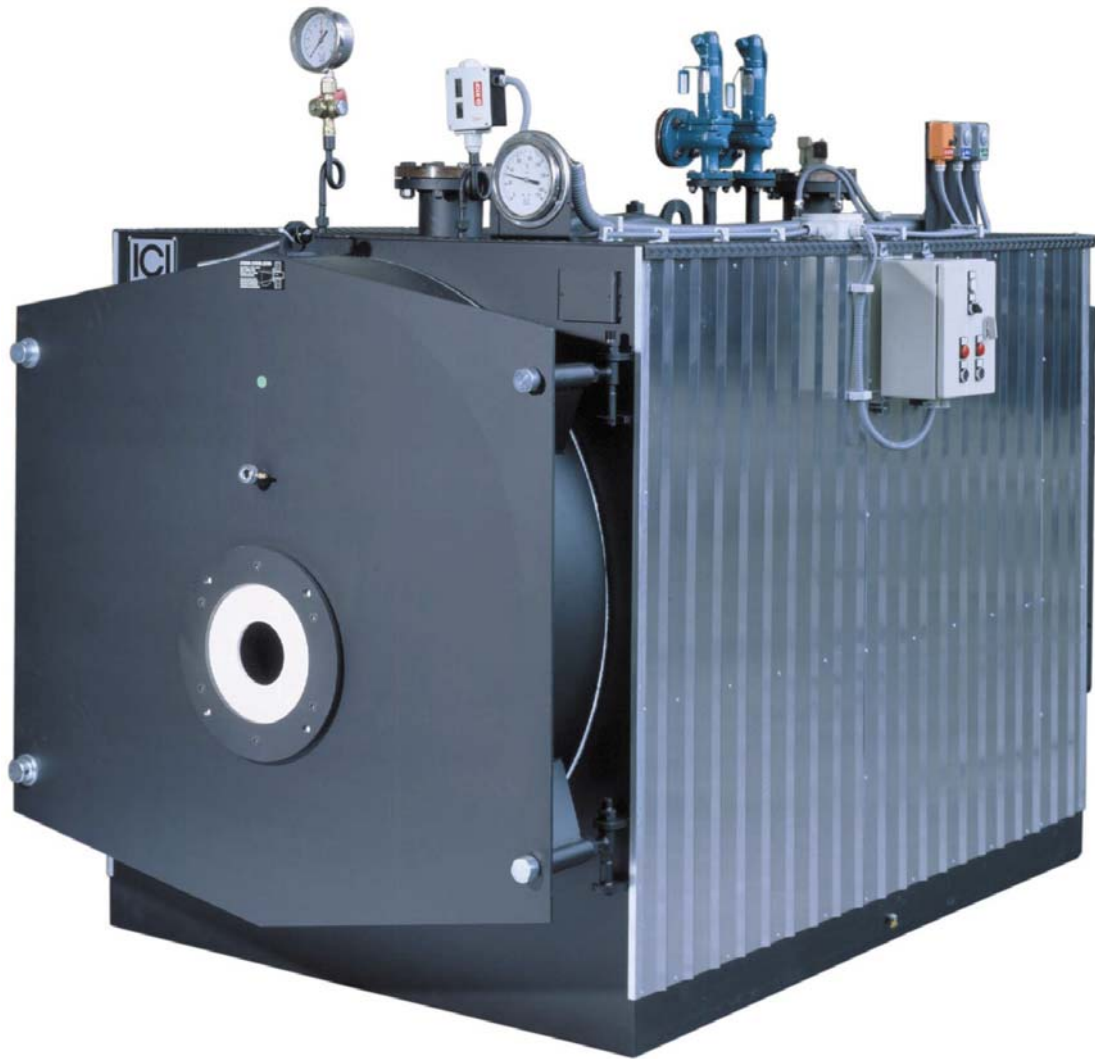

ASX

SUPERHEATED WATER GENERATOR

INDEX

1	TECHNICAL CHARACTERISTICS	2
1.1	GENERAL	2
1.2	TECHNICAL DATA	2
2	ACCESSORIES	3
2.1	PRESSURE.....	3
	Pressure gauge	3
	Operation pressure switch.....	4
	Safety pressure switch	4
	Safety valves	5
2.2	TEMPERATURE	5
	Thermostats	5
	Thermometer.....	5
3	INSTALLATION	6
3.1	THERMAL PLANT.....	6
3.2	SITING	6
3.3	WATER CONNECTIONS	6
3.4	ELECTRIC CONNECTIONS.....	7
3.5	SMOKESTACK	8
3.6	BURNER	8
	Boiler - Burner coupling.....	8
4	STARTING	9
5	MAINTENANCE	10
5.1	ORDINARY	10
5.2	SCHEDULED	10
5.3	CONSERVATION DURING WHEN OUT OF SERVICE.....	10
	Dry conservation.....	10
	Wet conservation.....	10
6	WATER CHARACTERISTICS	11
6.1	FEEDWATER - LIMIT VALUES (ENTERING THE BOILER)	11
6.2	BOILER WATER - LIMITING VALUES	12
6.3	FREQUENCY OF THE ANALYSES.....	12
7	FAULTY OPERATION	13

1 TECHNICAL CHARACTERISTICS

1.1 GENERAL

The superheated water heat generator are semiportable horizontal heaters with fire tubes suitable for pressurised combustion.

1.2 TECHNICAL DATA

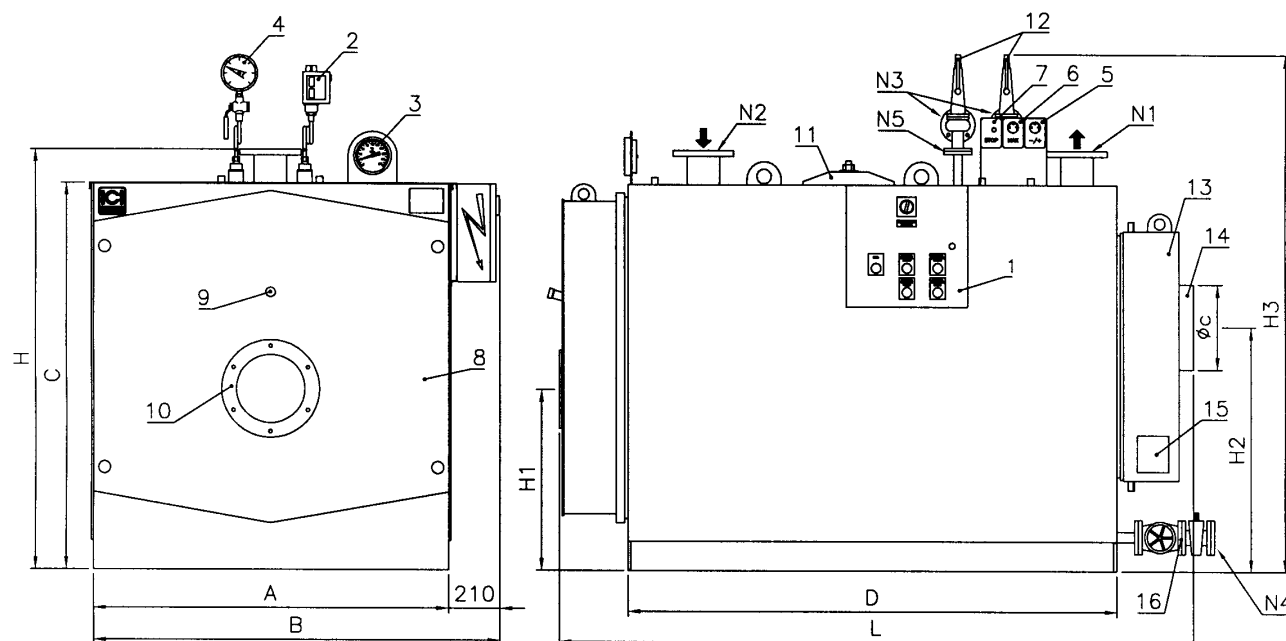

Fig. 1

LEGEND

- | | | | |
|----|-----------------------|----|-----------------------|
| 1 | Switchboard | 12 | Safety valves |
| 2 | Pressure switch | 13 | Rear flue gas chamber |
| 3 | Thermometer | 14 | Smokestack connection |
| 4 | Pressure gauge | 15 | Cleaning door |
| 5 | 1st flame thermostat | 16 | Drain unit |
| 6 | 2nd flame thermostat | N1 | Flow |
| 7 | Safety thermostat | N2 | Return |
| 8 | Front plate | N3 | Safety valves drain |
| 9 | Flame inspection hole | N4 | Boiler drain |
| 10 | Burner plate | N5 | Safety valves fitting |
| 11 | Inspection door | | |

Model	Heat output		Counter press. mbar	Size mm										Fitting DN					Weight * kg
	kcal/h	kW		A	B	C	D	H	H1	H2	H3	L	Øc	N1/N2	N3	N4	N5		
ASX 200	200.000	233	3,5	1080	1290	1240	1510	1360	575	720	1730	2100	250	65	40	32	25	1400	
ASX 300	300.000	349	3,5	1170	1380	1290	1510	1410	620	850	1780	2100	250	80	40	32	25	1600	
ASX 400	400.000	465	5,0	1170	1380	1290	1760	1410	620	850	1780	2300	250	80	40	32	25	1850	
ASX 500	500.000	581	4,5	1320	1530	1450	1760	1570	700	950	1940	2300	300	100	40	32	25	2200	
ASX 600	600.000	698	6,0	1320	1530	1450	2010	1570	700	950	1940	2550	300	100	40	32	25	2700	
ASX 800	800.000	930	5,5	1450	1660	1580	2010	1720	740	1000	2090	2600	350	125	40	32	25	3000	
ASX 1000	1.000.000	1163	7,0	1450	1660	1580	2310	1720	740	1000	2090	2900	350	125	40	32	25	3500	
ASX 1200	1.200.000	1395	8,0	1540	1750	1690	2520	1820	765	1200	2190	3100	400	150	40	32	25	4100	
ASX 1500	1.500.000	1744	6,5	1720	1930	1870	2720	2000	850	1200	2445	3400	450	150	50	32	32	5000	
ASX 1750	1.750.000	2035	7,5	1720	1930	1870	3020	2000	850	1200	2445	3700	450	150	50	32	32	6000	
ASX 2000	2.000.000	2326	8,0	1740	1950	1890	3020	2010	880	1380	2455	3700	500	150	50	40	32	7100	
ASX 2500	2.500.000	2907	9,0	1840	2050	1990	3520	2150	950	1450	2595	4250	550	200	50	40	32	8100	
ASX 3000	3.000.000	3488	9,5	1950	2160	2100	3770	2250	970	1500	2765	4550	600	200	65	40	40	9000	

* Data referred to 12 bar.

2 ACCESSORIES

The superheated water heat generator are fitted with a series of accessories that can be subdivided as follows:

- Safety accessories (safety valves, safety pressure switches, safety thermostat)
- Observation accessories (temperature gauges, pressure gauge, flame inspection)
- Control accessories (thermostat)

In the following description the accessories are subdivided as to the physical parameter they control (pressure and temperature).

2.1 PRESSURE

PRESSURE GAUGE (Fig. 2)

The pressure gauge is Bourdon type consisting of a flat elliptical section metal tube, bent to an arc. One end of the tube is open and communicates with the boiler where the pressure is to be measured; the other end, closed and free to move is connected by a lever system to a toothed arc and to the gauge indicator hand.

The gauge shows in red the design pressure.

The gauge is carried on a three-way valve to allow the following operations:

- Communication between boiler and gauge (normal operation position)
- Communication between gauge and the atmosphere (position necessary to purge the siphon)
- Communication between the boiler, the gauge and a test gauge (position necessary to verify the gauge)

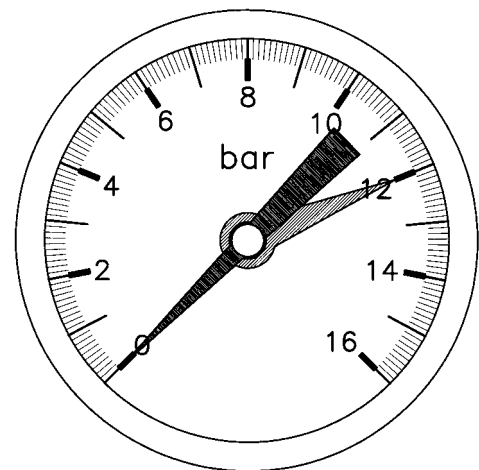

Fig. 2

OPERATION PRESSURE SWITCH

Device that controls the boiler pressure and holds the pressure between the set maximum and minimum values.

Instructions for adjustment.

The electric switch has three screws (2-1-3 from right to left).

On reaching the set pressure, the contact 2-1 switches to 2-3.

Adjustment of the pressure switch (Fig. 3):

- a) Turn the knob (1) until the scale indicator (2) reaches the pressure at which the burner shall restart;
- a) Remove the cover of the pressure switch and position the drum (3) at the value selected for the pressure differential (stopping the burner) as to the diagram Fig. 4.

Example:

- * Type of pressure switch: RT 5
- * Scale indicator: 9 bar
- * Drum indicator: 4 corresponding to 2,1 bar
- * Burner start: 9 bar
- * Burner stop: 11,1 bar

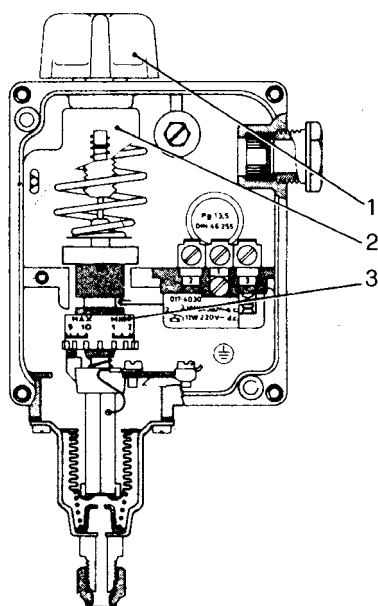

Fig. 3

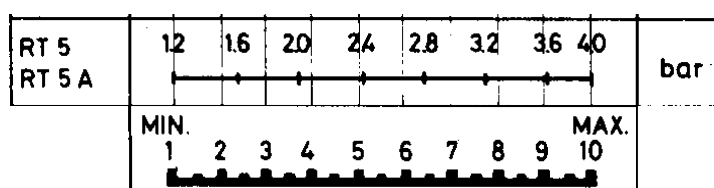

Fig. 4

SAFETY PRESSURE SWITCH

This switch is set at a higher pressure than the maximum of the control pressure switch, but always lower than the opening pressure of the safety valves.

The safety pressure switch acts in the case of a fault to the control pressure switch and stops the burner permanently. Restarting the burner can only occur after the water pressure has fallen and after a manual reset on the switchboard.

This pressure switch is adjusted in a similar manner to that of the control pressure switch, with the only precaution that the drum indicator is set to 1 so that the differential is effectively nil.

SAFETY VALVES

These valves have the function of discharging superheated water when the maximum design pressure of the boiler is reached.

The valves used on boilers are of the type **Spring** (Fig. 5).

The boiler operator must pay much attention to the safety valves and carry out careful and diligent maintenance. The safety valve is the most important and sensitive accessory on the boiler and represents the best guarantee that the internal pressure of the boiler does not exceed the design pressure.

As during normal operation of a boiler, the safety valve never acts, it is **good practice to check that the valve is free, i.e. that the valve plug is not stuck to the seat**, by acting on the side lever until the valve starts to discharge water.

WARNING

On first start-up, you must verify that safety valve adjustment is made to the boiler design pressure. Generally the spring safety valve is supplied already adjusted,

The safety valve installed on boilers must have the discharge piped to outside the boiler room. Particular care must be taken in designing the discharge line; we show some here.

- The discharge line should be of diameter at least equal to that of the discharge flange on the safety valve.
- Only wide radius curves must be used in the discharge line.
- The entire discharge line must be built to avoid the formation of condensation locks. There must be therefore adequate slopes to ensure complete drainage.

Particular care must be taken if the valve seat and plug are to be ground; if this operation becomes necessary due to leaks, use abrasives based on silicon carbide or oil based carborundum. Carry out the first grinding operation using fine grain abrasive, finishing with a very fine grain abrasive.

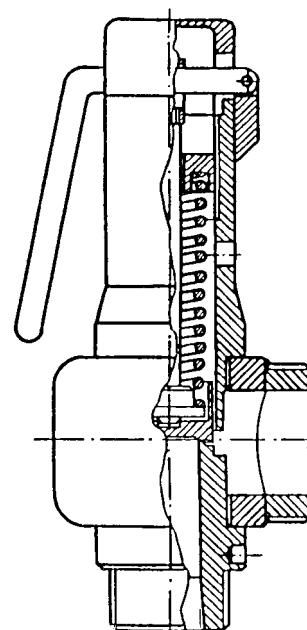

Fig. 5

2.2 TEMPERATURE

THERMOSTATS

There are usually two: one for limiting or regulating; the other for safety or locking.

- The limiting thermostat shuts down the burner when it has reached the temperature; and automatically restarts it at a predetermined value; moreover, it provides for a contact to actuate the second flame of the two stage burner.
- The safety thermostat locks the burner at a fixed temperature value and sends out an alarm signal. Re-starting occurs only after the cause of the alarm has been removed and the system has been reset by operating the reset button on the switchboard.

IMIT Thermostat: The contact breaker has three screws C-1-2. The C-1 connection closes at a temperature lower than the minimum and up as far as maximum. The C-2 connection is switched on at a temperature exceeding the maximum.

Gauging can be effected by operating the handle positioned on the thermostat box.

THERMOMETER (Fig. 6)

The stainless steel thermometer has a great dial, with a suitable full scale and 4000 mm capillary.



Fig. 6

3 INSTALLATION

3.1 THERMAL PLANT

Current regulations must always be observed. premises in which boilers will be installed should be sufficiently ventilated and permit access for ordinary and extraordinary maintenance operations.

3.2 SITING

Our boilers are supplied as units and do not need any foundation work. A flat even floor only is needed, that can be raised by 5-10 cm.

3.3 WATER CONNECTIONS

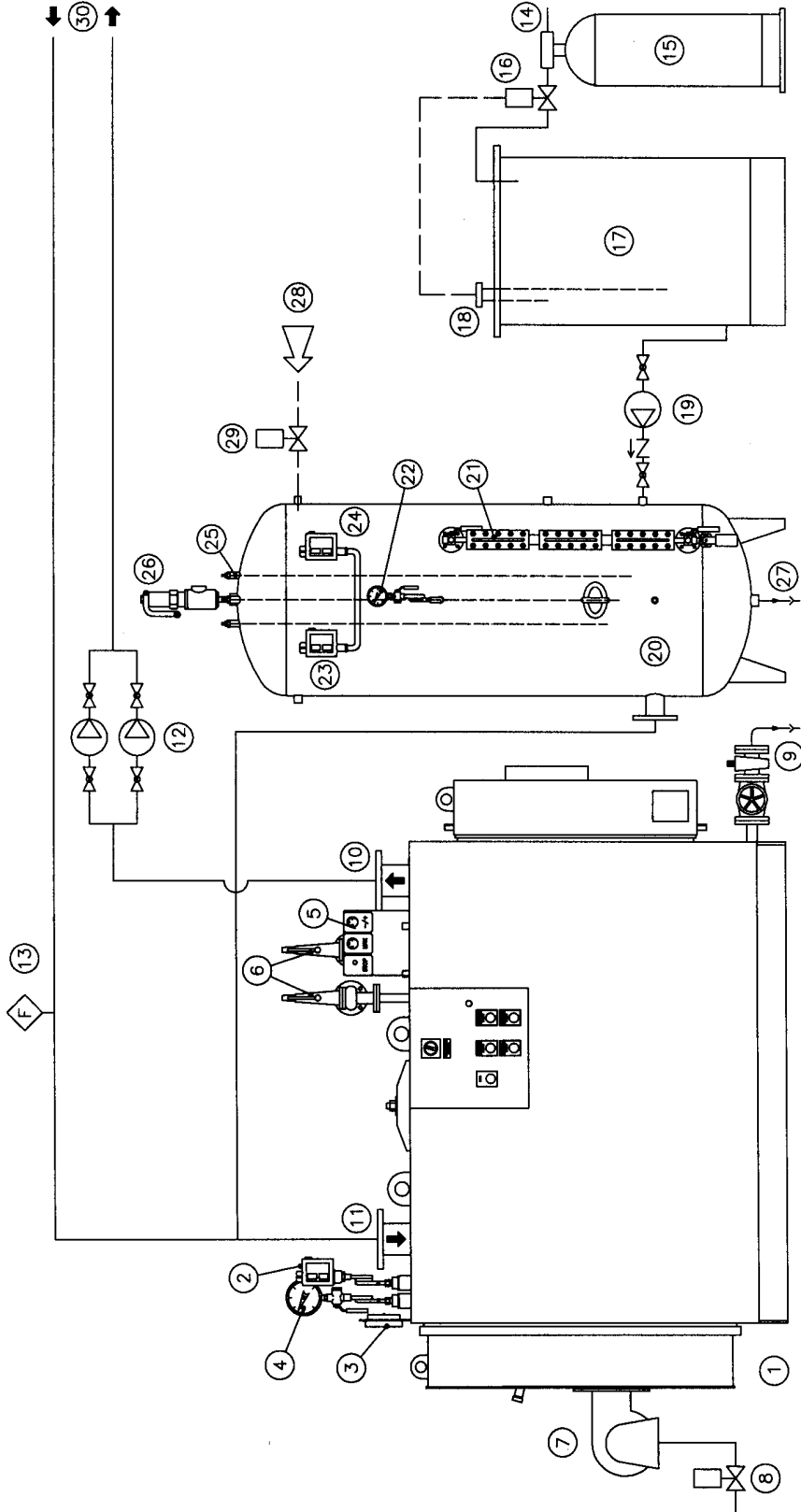

- LEGEND**
- 1 Boiler
 - 2 Safety pressure switch
 - 3 Thermometer
 - 4 Pressure gauge
 - 5 Thermostats
 - 6 Safety valves
 - 7 Burner
 - 8 Stop fuel electric valve
 - 9 Boiler drain
 - 10 Flow
 - 11 Return
 - 12 Pumps system
 - 13 Flow switch
 - 14 Water supply
 - 15 Water treatment
 - 16 Feed water electric valve
 - 17 Reserve water tank
 - 18 Water tank level control
 - 19 Reinstatement system pump
 - 20 Closed expansion vessel
 - 21 Level gauge
 - 22 Pressure gauge
 - 23 Feed air pressure switch
 - 24 Safety pressure switch
 - 25 Level control probes
 - 26 Expansion vessel safety valves
 - 27 Expansion vessel safety drain
 - 28 Feed air
 - 29 Feed air electric valve
 - 30 User service

Fig. 7 - System diagram

3.4 ELECTRIC CONNECTIONS

The boilers are provided with a switchboard (protection level IP 54) completely assembled to the various boiler accessories.

Before connecting the switchboard, make sure that the electric system has been correctly installed, checking in particular the efficiency of the earthing system.

Wiring diagram (SE 001/15)

WARNING: The wiring diagram of the switchboard shown here is indicative only. For details of the plant supplied, refer to the diagram supplied with the specific switchboard.

LEGEND

- B1 Boiler safety pressure switch
- B2 Boiler safety thermostat
- B3 Boiler limit thermostat
- B4 2nd flame thermostat (if present)
- F1 Auxiliary fuses 230 V
- F2 Auxiliary fuses 24 V
- H1 Siren
- H2 System ON lamp (white)
- H3 Maximum pressure exceeded lamp (red)
- H4 Maximum temperature exceeded lamp (red)
- K1 Boiler pressure safety relay
- K2 Boiler temperature safety relay
- Q1 Main switch
- S1 Boiler pressure safety reset button
- S2 Boiler temperature safety reset button
- T Transformer 0-230-400 12-0-12 V

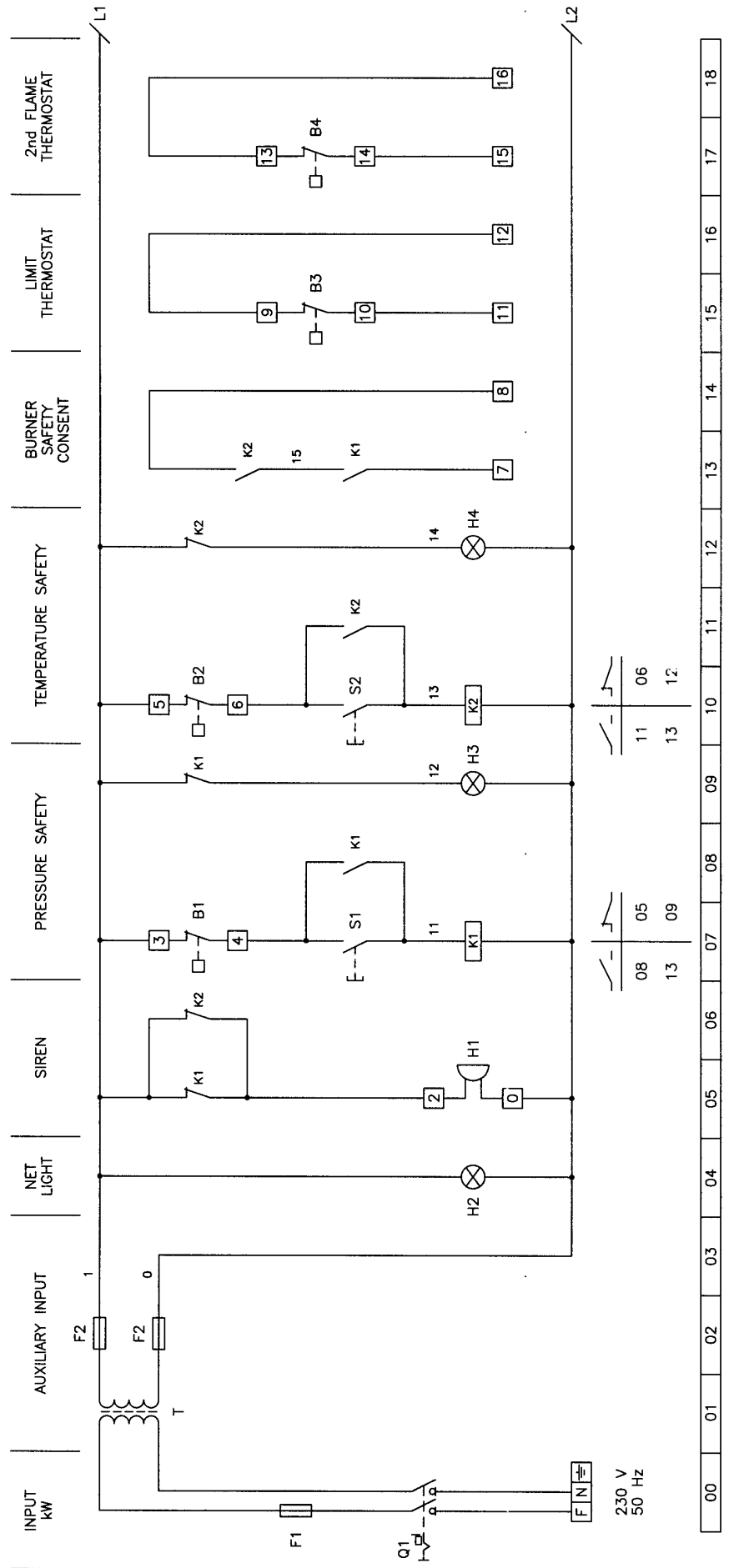

3.5 SMOKESTACK

The connection from the boiler to the base of the smokestack must slope upwards in the direction of the gas flow, with a slope that should be at least 10%. The path should be as short and as possible and the bends and connections designed as to the rules used in the design of air ducts.

For lengths of up to 2 metres, the same diameter as the boiler flue gas outlet can be used (see the technical specification table). For more tortuous paths, the diameter must be suitable increased.

The smokestack must in any case be dimensioned as to applicable regulations. It is advisable to pay great attention to the inside diameter, insulation, gas tightness, ease of cleaning and to the fitting required for taking flue gas samples for combustion analysis.

3.6 BURNER

To better answer to user demand, it is advisable to install a **two-stage burner** or a **modulating burner**; this avoids large pressure variations consequent on sudden stream demands.

Further, and above all with natural gas, every burner start-up is preceded by a long period of prevention of the combustion chamber, with consequent loss of heat to the smokestack.

BOILER - BURNER COUPLING

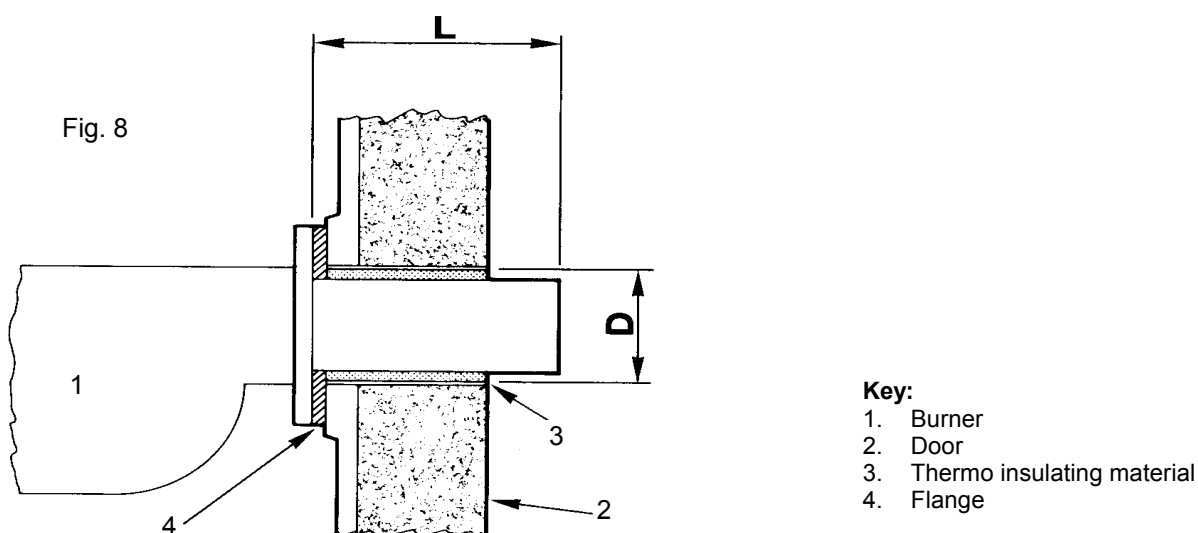

Verify that the spaces between the burner sleeve and the boiler door are suitable filled with flame-resistant ceramic insulation (Fig. 8).

The table shows the dimensions of the burner sleeves used on these boilers.

Boiler Type	L - Length of burner sleeve (mm)	D - Burner sleeve insertion hole (mm)
ASX 200	280 ÷ 330	180
ASX 300 ÷ 400	310 ÷ 360	225
ASX 500 ÷ 600	350 ÷ 400	280
ASX 800 ÷ 1000	370 ÷ 420	280
ASX 1200	370 ÷ 420	320
ASX 1500 ÷ 1750	420 ÷ 470	360
ASX 2000	480 ÷ 530	360
ASX 2500 ÷ 3000	480 ÷ 530	400

4 STARTING

First check to see that the fastenings are completely locked and that the blank discs provided in the case of hydraulic testing are removed.

Now check that the water pipes are clean by repeated washing out into the sewer before final filling.

Check that the front and back hatches are correctly closed.

WARNING: During the first starting up it is very important to tighten progressively the two nuts of the small door, little by little as the pressure increases.

Otherwise a dangerous situation is created owing to the drawing which, once it has occurred, renders the packing useless in addition to being risky for the staff employed in the station.

5 MAINTENANCE

5.1 ORDINARY

- Periodically purge the level gauges, probe holder if fitted and the boiler, to avoid the accumulation of sludge.
- Check the efficiency of the control and regulation instruments, examining carefully the electrical parts (connections included) and the mechanical parts (pressure switches); it is advisable to replace every year the ceramic probe-holders.
- Carry out burner maintenance (as to the specific instructions);
- Check the tightness of flange bolts and the state of the gaskets;
- Check the conditions of the boiler door internal covering;
- Clean the flue-gas tube bundle and the turbolators
- Carry out correct maintenance to the pump (bearings, mechanical seal)
- Check for wear to the discharge valves; these tend to wear more quickly, due to the abrasive effect of the sludge during blow-down;

5.2 SCHEDULED

All boilers must be periodically stopped for careful inspection and maintenance: the time interval between stops is established by experience, by the operating conditions, by the quality of the feedwater and by the type of fuel used.

Before entering the boiler shell for inspection or for cleaning, check carefully that there is no possibility of entry of water via the pipework to which the boiler is connected. Every valve must be locked and if necessary isolated by removing a piece of pipework or by inserting a blind flange.

The parts under pressure must be carefully examined internally to identify any encrustation, **corrosion** and other potential **sources of danger linked to the feed water**.

All deposits must be removed mechanically or chemically and **the effective thickness of the structures must be verified using suitable instruments to determine that they are equal to or greater than the design values**. All pustules or other types of corrosion must be scraped and cleaned with a steel wire brush to white metal. Leaks between fire tubes and tube plates must be carefully examined: any welding must be done in all cases observing legal obligations, without forgetting that a boiler is a pressure vessel with danger of explosion and subject to control by competent authorities.

During inspection also verify all the accessories, with priority to safety valves, level probes and pressure switches.

5.3 CONSERVATION DURING WHEN OUT OF SERVICE

Often during periods of disuse the worst cases of corrosion appear. The operations to be carried out to guarantee correct conservation of the boiler depend essentially on the duration of the stop.

The boiler can be subjected to dry conservation if the period of disuse is long, or to a wet conservation for short stops or if the boiler has a back-up function and must be ready to come on-line in a short time.

In both cases, the necessary operations tend to eliminate the causes of possible corrosion.

DRY CONSERVATION

The boiler must be drained and dried carefully, then placing in the boiler shell a hygroscopic substance (for example lime or silica gel etc)

WET CONSERVATION

The boiler must be filled completely, given that corrosion is a phenomenon that appears due to the simultaneous presence of water and Oxygen. Therefore all traces of Oxygen must be removed from the water, also avoiding the successive infiltration of air. There are substances that absorb Oxygen, such as hydrazine and Sodium Sulphite, but after their use the water alkalinity must be checked.

6 WATER CHARACTERISTICS

For generators with heating surface over 15 sqm, **there are some regulations that require limit values for water characteristics.** These values are listed in the tables below.

However, limits should be adopted for all generators as stated by qualified companies that recommend the type of treatment to be carried out basing on careful analysis of the available water. **Many faults and sometimes serious accidents are caused by the use of water with non-conforming features.**

6.1 FEEDWATER - LIMIT VALUES (ENTERING THE BOILER)

Tab.1

Characteristics	Unit of measurement	Pressure ≤ 15 bar	Pressure ≤ 25 bar
pH		7 ÷ 9,5	7 ÷ 9,5
Total hardness	mg/l CaCO ₃	10	5
Oxygen (1)	mg/l O ₂	0,1	0,05
Free Carbon Dioxide (1)	mg/l CO ₂	0,2	0,2
Iron	mg/l Fe	0,1	0,1
Copper	mg/l Cu	0,1	0,1
Oily substances	mg/l	1	1
Aspect	Clear, limpid, no persistent foam.		

- (1) These values are valid to have a thermo degassing device. Without degassing device, the temperature of the tank water must be increased to at least 80 Celsius (see chapter 2.3. - Feeding) to reduce the content of dissolved gasses (O₂ and CO₂). Chemical deoxygenators must be used to remove completely the oxygen from the feed water and reduce as much as possible CO₂ corrosive effects.

6.2 BOILER WATER - LIMITING VALUES

Tab.2

Characteristics	Unit of measurement	Pressure ≤ 15 bar	Pressure ≤ 25 bar
pH		9 ÷ 11	9 ÷ 11
Total alkalinity	mg/l CaCO ₃	1000	750
Total hardness	mg/l CaCO ₃	10	5
Conductivity (4)	μS/cm	8000	7000
Silica	mg/l SiO ₂	150	100
STD (4)	mg/l	3500	3000
Conditioner (2)			
Aspect	Clear, limpid, no persistent foam		

(1) To maintain in the boiler the parameters of alkalinity and silica within the prescribed or recommended limits, the boiler must be purged, if possible continuously. The values of the concentrations in the feedwater and in the boiler water are linked to the continuous purge by the following relationship:

$$S\% = 100 \frac{Ca}{Cc}$$

where

- S% = Percentage of purge with respect to the feed water supplied to the boiler;
- Ca = Real concentration of a certain salt or ion in the feed water
- Cc = Maximum allowed concentration in the boiler for the same salt.

- (2) Correct management presupposes normally the use of conditioners, whose dosages and limits are in relation to the nature and characteristics of the additives themselves.
- (3) Determined on a filtered sample
- (4) The two parameters have the same physical meaning but the values can be correlated only if the chemical composition of the water is known.

6.3 FREQUENCY OF THE ANALYSES

The frequency of analysis is determined evidently as a function of the use of the boiler and of the quality of the water used; it is advisable in any case to check the pH, the total hardness and the alkalinity of the feed and boiler waters at least every two days. Once a month, especially under conditions of variable operation, it is advisable to subject meaningful samples of the boiler and feed waters to complete analysis.

7 FAULTY OPERATION

FAULT	PROBABLE CAUSE	SUGGESTED REMEDY
Safety valve/s opening	Maximum pressure exceeded, as set on the valve. Must be equal to the boiler design pressure.	Adjust the safety pressure switches and / or limit switches.
	Loss of the adjustment of the safety valve	Check and then adjust the valve using a reference gauge
Small leaks from the safety valve/s	Dirt on the valve seat	Clean the seat by opening the valve manually a few times
	Marks on the valve seat	Dismantle the valve and regrind the valve seat with very fine abrasive.
Pressure safety switch operates	Pressure limit switch set too high	Adjust the pressure limit switch
	Pressure limit switch faulty	Replace the pressure limit switch
	Pressure switch pipe coil blocked	Clean or replace the pipe coil
Burner always ON	Erroneous electrical connection to the panel	Consult the wiring diagram
	Control and/or safety pressure switches inactive	Check the adjustment of the pressure switches Check the pressure switch connections to the control panel
Burner always OFF	Problems with the burner	See the specific burner Manual
	Burner fuses interrupted	Replace the fuses
	No consent to the burner from the control thermostat	Replace the control thermostat
	Erroneous connection to the control panel	Consult the wiring diagram



Via G. Pascoli, 38 (S.S. 434 - km 9) S. Maria di Zevio - VERONA - ITALIA
Tel. 045/8738511 - Fax 045/8731148

The data reported are indicative only and are not binding. Our company reserves the right to introduce alterations at any time as it deems fit and proper for the development of the product.